



Model CP-6 Specifications

- Freezer temperature range -20°F to +10°F
- Refrigeration: Eutectic Cold Plate, 14-hour charge
- Electrical 120v / 60Hz
- ETL Listed (Accepted as NSF & UL)
- Ice Cream Tubholders or Gelato Panholders included
- Sliding Lexan clear lids with stainless steel frame.
- Steel Cart Frame and Freezer - powder-coated white baked enamel finish
- Custom Graphics included
- Defrost drain for easy cleaning
- Umbrella: 9' wood market 1-color umbrella with screenprinted fabric **or** 6' aluminum two-color vinyl umbrella w/logo
- 6" solid rubber casters, two w/brakes.
8" caster upgrade available.
- 90mm Pentane insulation, 100% CFC free
- Keeps product cold 8-10 hours without electricity
- Approximate weight: 273 lbs
- Lock and key included
- Internal Dimensions:
35" W x 31" H x 23" D

Total Capacity:
10 3-gal. ice cream tubs or
14 5-liter gelato pans

Freezer Warranty

1 Year Parts and Labor
(accessories excluded)
5 Years Compressor (part only)

Umbrella Warranty

1 year

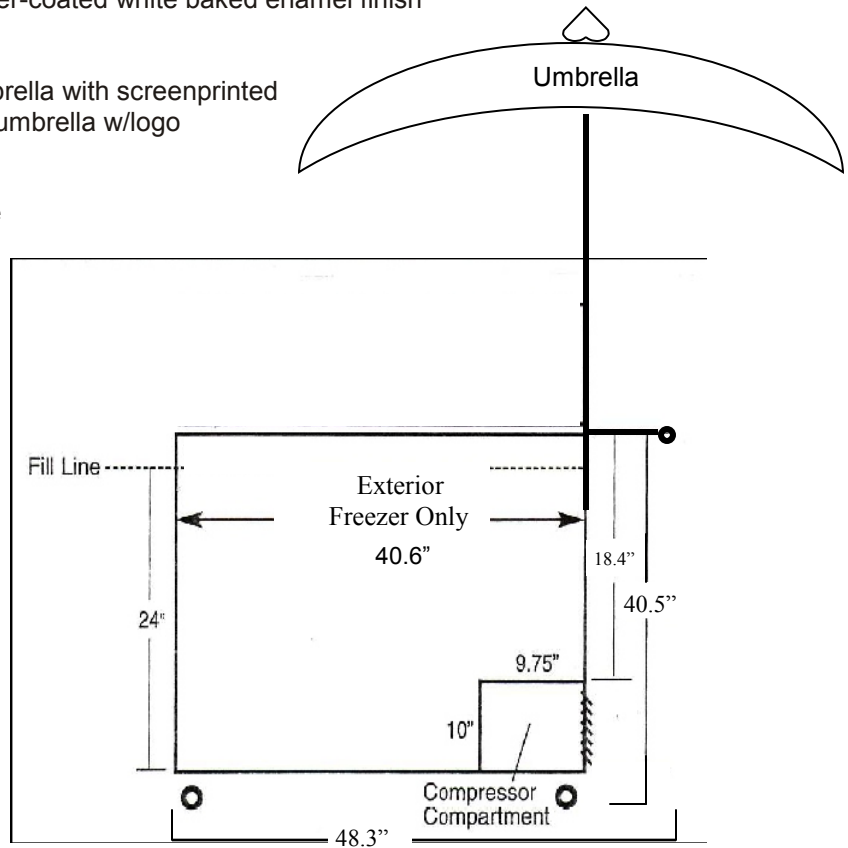

Patented Portable Ice Cream Sink

- All restaurant-quality stainless steel construction
- 2.5 gallon hot water heater (UL Listed)
- electric water pump (UL Listed)
- heavy duty lockable wheels
- NSF certified dipwell
- 15-gallon waste water tank
- 7-gallon fresh water tank (with easy alternate connection to standard garden hose)
- Runs on regular 110v electricity
- Amp requirements:
water heater=10.5, water pump=.4, Total=15.5
- All electrical parts are UL listed.
- 40" H x 33.5" W x 18.5" D
- Approximate Weight 155 lbs.
- Three-compartment ware-washing station available

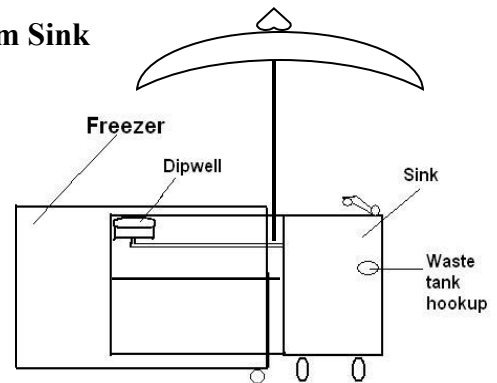

Sink Warranty

Pump: 2 years
Water Heater: 5 years
All Other Parts: 1 year