



A10-SG Specifications

Freezer temperature range -15°F to +7°F
 Refrigerant CFC-free R-134a
 Electrical 120v / 60Hz
 UL listed to NSF/ANSI 7

FEATURES

Tubholders and skirts included
 Tempered glass sliding lids or
 Solid insulated sliding lids
 Durable white powder-coated
 enamel finish
 Custom Graphics included
 Defrost drain for easy cleaning
 Tempered glass sneeze guard
 with aluminum frame or
 Fold-down Lexan sneezeguard
 Model A10-B Freezer
 External Dimensions
 L x W x H
 59" x 27.75" x 34.65" (freezer only)
 Add 12" to height for sneezeguard
 Add 4" to height for cart casters

Warranty

2 Year Parts and Labor

5 Years Compressor (part only)

Display /Storage

Ten 2.5 or 3-gal. tubs / eight additional
 Gross Cu Ft

17.5

All restaurant-quality stainless steel construction
 2.5 gallon hot water heater (UL Listed)
 electric water pump (UL Listed)
 heavy duty lockable wheels
 includes dipwell (NSF approved) and waste water
 tank
 7-gallon fresh water tank (with easy alternative
 connection to standard garden hose)
 15-gallon waste water tank
 Runs on regular 110v electricity
 Amp requirements:
 water heater=10.5, water pump=.4, Total=15.5
 All electrical parts are UL listed.
 40" H x 33.5" W x 18.5" D

Dipping Cabinet

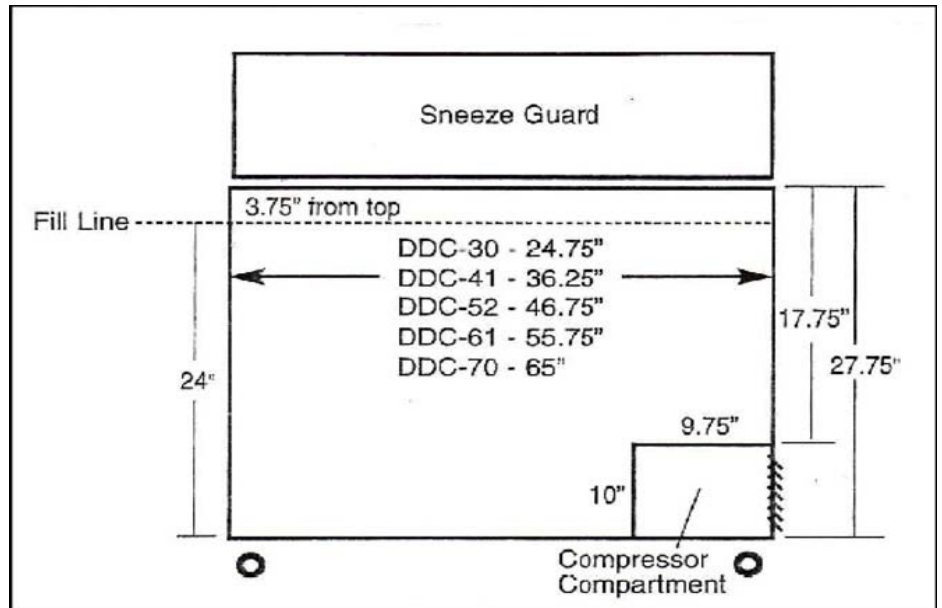

Portable Ice Cream Sink

